

RYA CYMRU WALES ZONE CHAMPIONSHIPS

CARDIFF BAY YACHT CLUB

24TH & 25TH SEPTEMBER 2016

THE ORGANISING AUTHORITY IS THE ROYAL YACHTING ASSOCIATION

in conjunction with Cardiff Bay Yacht Club

SAILING INSTRUCTIONS

1. RULES

The regatta will be governed by the rules as defined in *The Racing Rules of Sailing 2013-17*.

- 1.1 In case of conflict with the Notice of Race these Sailing Instructions shall prevail. This changes rule 63.7.

2. NOTICES TO COMPETITORS

- 2.1 Notices to competitors will be posted on the official notice board to the right of the entrance of the Yacht Club.

3. CHANGES TO SAILING INSTRUCTIONS

Any change to the Sailing Instructions will be posted not less than 1 hour before the scheduled start time of the class on the day it will take effect, except that any change to the schedule of races will be posted by 19:00 hours on the day before it will take effect.

4. BRIEFING

There will be a competitors briefing at 10.30am on Saturday in the Main Bar on the 1st floor of the Yacht Club.

5. SIGNALS MADE ASHORE

- 5.1 Signals made ashore will be displayed on flag staffs at the South end of the Yacht Club. When a signal is displayed over an area, class, or fleet flag it applies to that area, class, or fleet only.
- 5.2 Boats may not launch until Flag R is displayed with a sound signal. (Our intention is that the warning signal will be made not less than 20 minutes after Flag R is displayed or not before the scheduled time, whichever is later).
- 5.21 The Onboard Regatta Fleet may not launch until the Onboard White Flag is raised with a sound signal. Launching and race times' may be further communicated by the Regatta fleet coaches assigned to this course area.
- 5.3 Flag L with a sound means: 'A notice to competitors has been posted'.
- 5.4 When Flag AP is shown ashore race signal AP is changed in that "1 minute' is replaced by 'not less than 20 minutes'. Launching will start approximately 5 minutes after AP is lowered and Flag R is raised. This changes race signal AP.



6. SCHEDULE OF RACES

- 6.1 The series will consist of up to 10 races (Dinghy fleet). The Regatta & Windsurf Fleet may race up to 10 races.
- 6.2 Races will start at the following times each day (exact racing programme will be clarified on the day):

Dinghy

| Day | Course | Races (up to a maximum of 10 races) | Time of Warning Signal | |
|----------|-----------------|-------------------------------------|--|--|
| Saturday | Dinghy (Yellow) | Up to 6 Races | Scheduled time of warning signal for first race 11:55 | Optimist (Outer Loop) Topper (Inner loop) General Handicap (Inner Loop) |
| Sunday | Dinghy (Yellow) | Up to 5 Races | Scheduled time of warning signal for first race 10:25 | Optimist (Outer Loop) Topper (Inner loop) General Handicap (Inner Loop) |

Regatta Fleet

| Day | Course | Races (up to a maximum of 10 races) | Time of Warning Signal |
|----------|----------------|-------------------------------------|---|
| Saturday | Regatta (Blue) | Up to 6 races | Race Training or Scheduled Races from Noon |
| Sunday | Regatta (Blue) | Up to 5 races | Race Training or Scheduled Races from 10:30am |

Windsurf fleet





| Day | Course | Races (up to a maximum of 10 races) | Time of Warning Signal |
|----------|----------------|-------------------------------------|--|
| Saturday | Regatta (Blue) | Up to 6 races | Scheduled time of warning signal for first race 11:55 |
| Sunday | Regatta (Blue) | Up to 5 races | Scheduled time of warning signal for first race 10:25 |

- 6.4 Races will start as soon as practically possible after the finish of the previous race.
- 6.5 To alert boats that a race or sequence of races will begin soon, an orange flag will be displayed with one sound signal at least 5 minutes before the warning signal is displayed.
- 6.6 No Warning signal will be made after 15:00 on Sunday 25th September 2016.

7. CLASS FLAGS

Class flags will be:

Dinghy

| Class | Description | Picture |
|------------------|--------------|---|
| Topper | Code Flag T | T  |
| Optimist | Code Flag O | O  |
| General Handicap | Code Flag G | G  |
| Windsurf fleet | Code Flag M | M  |
| Regatta fleet | OnBoard Flag |  |

8. RACING AREAS

- 8.1 Colours Yellow and Blue designate racing areas. These colours will be used for identifying flags ashore and on committee boats if required.
- 8.2 The racing areas will be posted on the Notice Board.
- 8.3 Classes are assigned to racing areas as follows:

| Area | Classes |
|--------|---|
| Yellow | Optimist, Topper, General Handicap |
| Blue | Windsurf, Regatta Optimist, Regatta Topper, Regatta Handicap, |

- 8.4 A safety boat in close attendance to a craft or competitor in difficulty is an obstruction.

9. THE COURSES

- 9.1 The courses are described in Appendix A
- 9.2 Course signals will be displayed on a board on the starboard side of the race committee signal boat.
- 9.3 If no signal is displayed the Optimists will sail an outer loop O2 and the Topper and General Handicap will sail the inner loop I2.

10. MARKS

- 10.1 Dinghy Course marks will be Orange inflatable buoys. Windsurf & Regatta fleet marks will be Buoys with flags on them. Full descriptions & positions will be given on the day.
- 10.2 New marks, as provided in instruction 12, will be of the same shape and colour as the original marks.
- 10.3 Starting marks will be a race committee boat at the starboard end (including any buoy, object or boat attached to it), and a race committee boat at the port end (including any

buoy, object or boat attached to it) or an orange buoy or buoy with an orange flag at the port end.

10.4 Finishing marks will be a race committee boat and a blue inflatable buoy.

11. THE START

11.1 The starts will be started in accordance with RRS Rule 26

| Title | Minutes Before Starting Signal | Flag & Sound |
|-----------------|--------------------------------|---|
| Warning | 5 minutes | Class Flag ; 1 sound signal |
| Preparatory | 4 minutes | Either Flag P or Flag I or Flag U or Black Flag up ; 1 sound signal |
| 1 minute period | 1 minute | Either Flag P, I, U, or Black down and one long sound signal |
| Starting | 0 minute | Class Flag Removed ; 1 sound signal |



11.2 The starting line will be between staffs displaying orange flags on the starting marks.

11.3 Boats whose warning signal has not been made shall avoid the starting area.

11.4 A boat starting later than 4 minutes after her starting signal will be scored Did Not Start. This changes rules A4 and A5.

11.5 If a start under rule 30.3 (Black Flag Rule) is recalled or abandoned after the starting signal, the championship numbers of the boats identified in the triangle will be displayed on the race committee signal vessel for a minimum of 3 minutes. A repeated sound signal will be made as the numbers are displayed. Any boat so notified that she has been disqualified shall not sail in any restart or re-sail of that race. This changes rule 30.3.

11.6 If flag U has been displayed as the preparatory signal, no part of a boat's hull, crew or equipment shall be in the triangle formed by the ends of the starting line and the first mark during the last minute before her starting signal. If a boat breaks this rule and is identified, she shall be disqualified without a hearing but not if the race is restarted or resailed or postponed or abandoned before the starting signal. This changes rule 26 *Starting Races* and RRS 63.1. When flag U is used as the preparatory signal rule *Individual recall* does not apply. The scoring abbreviation for a flag U penalty is UFD. This changes A11 *Scoring Abbreviations*.

12. CHANGE OF THE NEXT LEG OF THE COURSE

To change the next leg of the course, the race committee will move the original mark (or the finishing line) to a new position, or lay a new mark and remove the original mark as soon as practicable. When in a subsequent change a new mark is replaced, it will be replaced by an original mark.

13. THE FINISH

13.1 The finishing line will be between a staff displaying a blue flag on the Race Committee boat at the Port end and a blue inflatable buoy or buoy with a blue flag.

13.2 A blue flag means that the Race Committee boat is in position at the finishing line.

13.2 Back markers may be given their finish taken on the course by a Race Committee boat displaying Flag W.



14. TIME LIMITS & TARGET TIMES

Time limits and target times are as follows:

| Class | Time limit | Target time |
|-------------|------------|-------------|
| All classes | 50 minutes | 30 minutes |

15. PENALTIES

- 15.1 Appendix P (Special Procedures for Rule 42) will apply as changed by instruction 15.2.
- 15.2 Rule P2.3 will not apply and rule P2.2 is changed so that it will apply to any penalty after the first one.

16. ADVISORY & ARBITRATION HEARINGS; EXONERATION PENALTY

16.1 Exoneration Penalty

- 16.1.1 A boat that may have broken a rule of Part 2, rule 31 or rule 42, may, after finishing the race concerned and before the start of a related protest hearing, notify the Race Committee that she accepts a 30% scoring penalty as stated in rule 44.3(c), except that the minimum penalty is two places provided that does not result in a score worse than DNF. This penalty does not reverse an OCS score, a disqualification under rule 30.3 or a penalty under Appendix P. It is not available for a breach of rule 2 or of class rules or for gross misconduct under rule 69. Nor is it available to a boat that caused injury or serious damage, or gained a significant advantage by her breach: in these circumstances, her penalty is to retire.
- 16.1.2 When an Exoneration Penalty is accepted,
 - (a) Neither the boat nor a protest committee may then revoke or remove the penalty.
 - (b) The boat shall not be penalized further in a protest hearing when the protest committee decides that it was appropriate to the facts found and the applicable rules.

16.2 Advisory Hearing

When there is an incident that will not result in the lodging of a protest or a request for redress, a boat, Protest Committee or Race Committee may request an advisory hearing with the race office, and notify any boat involved in the incident. . An Adviser will then call a hearing to learn what may have happened and will state whether any rule appears to have been broken, and by which boat. A boat may as a result notify the Race office that she accepts an Exoneration Penalty when it applies to the incident, or choose to retire..

16.3 RYA Arbitration

- 16.3.1 When a protest or request for redress is lodged, a boat may at the same time request RYA Arbitration, or the Protest Committee or Race Committee may offer it.
- 16.3.2 If the parties and a member of the protest or race committee agree that RYA Arbitration is suitable, an Arbitrator (who may be that member of the Protest Committee) will call a hearing conforming to Section B of Part 5 of the Racing Rules of Sailing, except that rule 64.1(a) will not apply. Instead when the Arbitrator decides that a boat that is a party to the arbitration hearing has broken a rule for which the Exoneration Penalty is available, the party will be invited to accept that penalty, and, if it is accepted by a protested boat, the protesting boat will be allowed to withdraw the protest, changing rule 63.1.
- 16.3.3 When there is not an agreement to use RYA Arbitration, or when, after RYA Arbitration, a protest is not withdrawn or the Exoneration Penalty is not applicable to the facts, there will be a normal protest hearing, at which the Arbitrator may be a member of the Protest Committee. Rule 66 and 70 (reopening and appeal, respectively) do not apply to the arbitration decision since this is not a protest committee decision or procedure. . A boat may still accept an Exoneration Penalty at any time before the start of a protest hearing and receive its protection from further penalization. She may also retire.
- 16.3.4 When redress is offered and accepted at the RYA Arbitration, all parties the Protest Committee or Race Committee may seek to have this reviewed by asking for a full hearing. When redress is offered and not accepted, or not offered at all, the boat may have her request heard before a Protest Committee.

17. PROTESTS & REQUESTS FOR REDRESS

- 17.1 Boats intending to protest or request redress for an incident on the race course shall inform the race committee signal boat at the port end of the finish line. If they do not finish they shall inform either a jury boat or a support boat as soon as practicable after they retire. This adds to the requirements of RRS 61.1 for a protest or request for redress to be valid.
- 17.2 Protest forms are available at the race office in the clubhouse. Protests and requests for redress or reopening shall be delivered there within the appropriate time limit.
- 17.3 For each class or fleet the protest time limit is 30 minutes after the last boat has finished the last race of the day.
- 17.4 Notices will be posted within 30 minutes of the protest time limit to inform competitors of hearings in which they are parties or named as witnesses. The location and time of hearings will be posted.
- 17.5 Notices of protests by the race committee or protest committee will be posted to inform boats under rule 61.1(b).
- 17.6 Declarations for one or two turn penalties shall be made at the race office.
- 17.7 Breaches of instructions 5, 11.3, 19, 20, 21, 23, 24 and 25 will not be grounds for protest by a boat. This changes rule 60.1. Penalties for these breaches may be less than disqualification if the protest committee so decides.
- 17.8 On the last scheduled day of racing a request for reopening a hearing shall be delivered:
- (a) Within the protest time limit if the requesting party was informed of the decision on the previous day.
 - (b) No later than 30 minutes after the requesting party was informed of the decision on that day. This changes rule 66.
- 17.9 On the last scheduled day of racing a request for redress from a protest committee decision shall be delivered no later than 30 minutes after the decision was posted. This changes rule 62.2.

18. SCORING

- 18.1 One race is required to be completed to constitute a regatta for all boats.
- 18.2 When fewer than three races have been completed, a boat's series score will be the total of her race scores.
When three to eight races have been completed, one race score will be excluded.
When nine or more races have been completed, two race scores will be excluded.
- 18.3 To request correction of an alleged error in posted race or series results, a boat shall complete a scoring enquiry form available at the race office.
- 18.4 The scoring abbreviation for a discretionary penalty imposed under instruction 17.7 will be DPI.

19. SAFETY REGULATIONS

- 19.1 All competitors shall wear a personal flotation device at all times when afloat, except briefly when changing or adjusting clothing or personal equipment. Wet suits and dry suits are not considered personal flotation devices. This changes rule 40.1
- 19.3 A boat that retires from a race shall notify the race committee or a safety boat as soon as possible.
- 19.4 Boats wishing to sail ashore before the end of the day's racing shall not do so unless authorized by a safety boat. The safety boat will instruct boats in the procedure for returning ashore.
- 19.5 Boats shall follow the instructions of the safety boats. Infringements will be reported to the race committee, which may protest the boat. Boats penalised under this instruction may be scored DNE, or such other penalty that the protest committee may decide. This changes rule 64.1(a).

- 19.6 **Outside Help:**
Penalties for breaches of rule 41 (Outside Help) will be at the discretion of the protest committee. Any outside help shall be reported to the protest committee on a form available from the race office or the protest desk before the protest time limit on the day concerned.
- 20. TALLYING**
- 20.1 Each competitor shall, in person, tally out before launching, and tally in on return from racing. The tally board will be at the top of the main slipway.
- 20.2 The time for a boat to tally out ends when the boat is launched. The penalty for failing to tally out is 10% (rounded up) of the number of boats in her first race of the day, added to her score without a hearing.
- 20.3 A boat that fails to tally out must request and receive permission to remain afloat from a safety official before starting any race. A boat in this situation that starts a race before receiving such permission will be scored DNC for that race without a hearing. This changes rules 35 and A4.
- 20.4 The time for a boat to tally in finishes ten minutes after the last boat in her class is ashore. The penalty for failing to tally in is 10% (rounded up) of the number of boats in her last race of the day, added to her score, without a hearing.
- 20.5 If a competitor fails to tally in or out three times at an event, on the third time the penalty will be DSQ from the race concerned without a hearing.
- 20.6 An announcement will be made when boats may tally out.
- 21. REPLACEMENT OF CREW OR EQUIPMENT**
- 21.1 Substitution of competitors will not be allowed without prior written approval of the race committee.
- 21.2 Substitution of damaged or lost equipment will not be allowed unless approved by the race committee. Requests for equipment substitution shall be submitted in writing using forms available from the race office or the protest desk, which shall be delivered to the protest desk before the protest time limit on the day the replacement equipment has first been used. Failure to comply with this requirement, the refusal of the request, or the failure of any replacement equipment to comply with the class rules, will result in the boat being scored DNE for the race or races concerned.
- 22. OFFICIAL BOATS**
The crews of all Official Boats are designated members of the race committee.
- 23. TRASH DISPOSAL**
Trash may be placed aboard support, rescue and race committee boats.
The penalty for breaking rule 55, Trash Disposal, is at the discretion of the protest committee (DPI) and may be less than disqualification.
- 24. BERTHING**
Boats shall be kept in their assigned spaces in the boat park.
- 25. RADIO COMMUNICATION**
A boat shall neither make radio transmissions while racing nor receive radio communications not available to all boats. This restriction includes mobile telephones.

26. DISCLAIMER OF LIABILITY

Risk Statement

RRS Rule 4 of the Racing Rules of Sailing states: "The responsibility for a boat's decision to participate in a race or to continue racing is hers alone."

Sailing is by its nature an unpredictable sport and therefore inherently involves an element of risk. By taking part in the event, each competitor agrees and acknowledges that:

- a) They are aware of the inherent element of risk involved in the sport and accept responsibility for the exposure of themselves, their crew and their boat to such inherent risk whilst taking part in the event;
- b) They are responsible for the safety of themselves, their crew, their boat and their other property whether afloat or ashore;
- c) They accept responsibility for any injury, damage or loss to the extent caused by their own actions or omission;
- d) Their boat is in good order, equipped to sail in the event and they are fit to participate;
- e) The provision of a race management team, patrol boats and other officials and volunteers by the event organiser does not relieve them of their own responsibilities;
- f) The provision of patrol boat cover is limited to such assistance, particularly in extreme weather conditions, as can be practically provided in the circumstances;

27. INSURANCE

Each participating boat shall be insured with valid third-party liability insurance with a minimum cover of £2 million per event or the equivalent.

APPENDIX A - COURSE DIAGRAMS

Course O- Outer Loop with reaching finish

O1

Start-1-2-3-finish

O2

Start-1-2-3-2-3-finish

O3

Start-1-2-3-2-3-2-3-finish

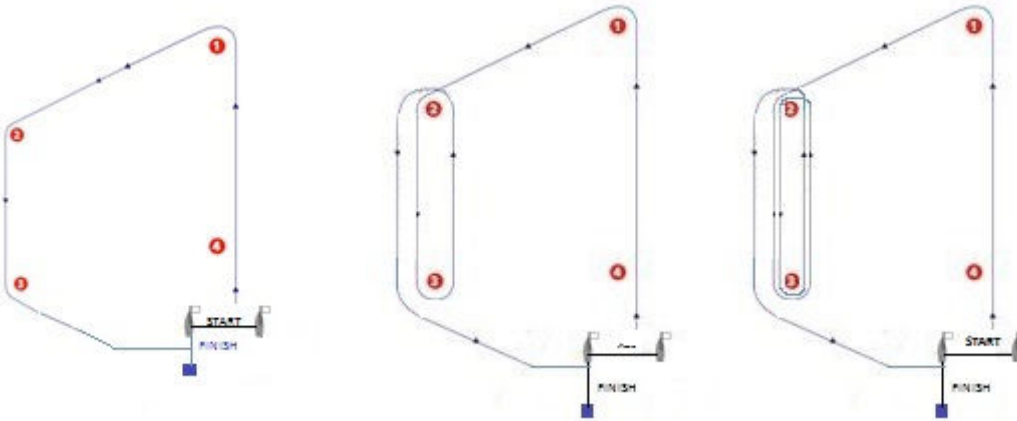

Course I- Inner Loop with reaching finish

I1

Start-1-2-3-finish

I2

Start-1-4-1-2-3-finish

I3

Start-1-4-1-4-1-2-3-finish

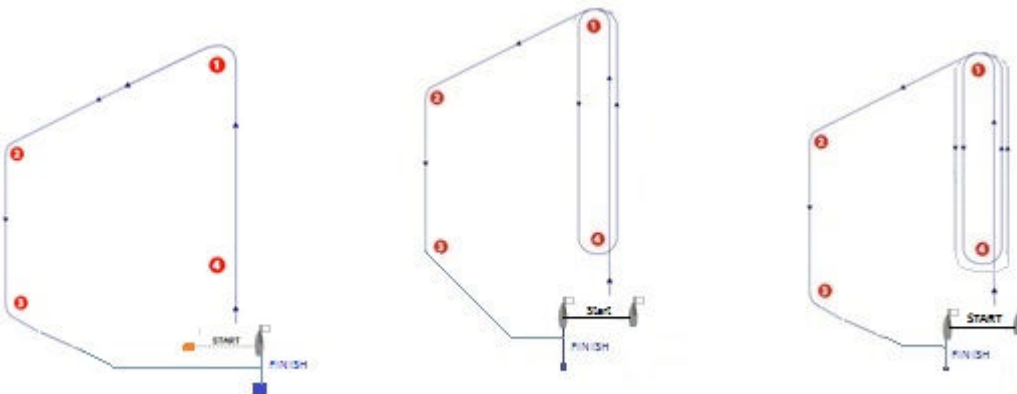

Course L- Windward/Leeward

L1

Start-1-finish

L2

Start-1-4-1-finish

L3

Start-1-4-1-4-1-finish

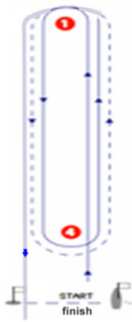

B- Box (this course is likely to only be used for windsurfers)

B1

Start-1-2-3-finish

B2

Start-1-2-3-4-1-2-3-finish

B3

Start-1-2-3-4-1-2-3-4-1-2-3-finish

